

ALL OPERATIONS MUST BE CARRIED OUT BY QUALIFIED PERSON

- ① Fix the bracket on the ceiling (use appropriate anchors depending on the type of ceiling).

Fissare la staffa a soffitto (utilizzare tasselli appropriati in base al tipo di soffitto).

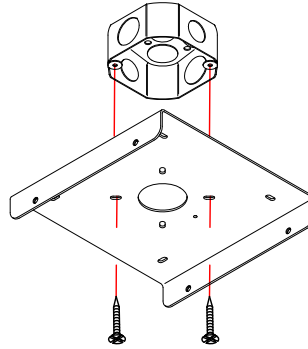

USA

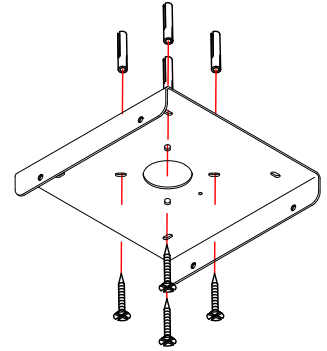

CE

- ② Hold the lamp carefully from the central beam and connect the wires cables following the driver instruction attached.

Hold the lamp carefully from the central beam and connect the wires cables following the driver instruction attached.

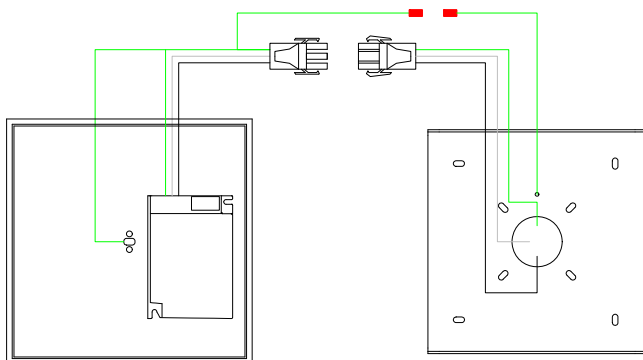

USA

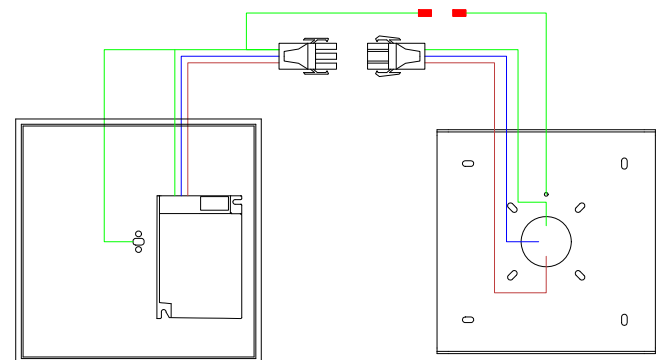

CE

ALL OPERATIONS MUST BE CARRIED OUT BY QUALIFIED PERSON

- ③ Fix the lamp to the bracket with the screws provided.

Fissare la lampada alla staffa con le viti fornite.

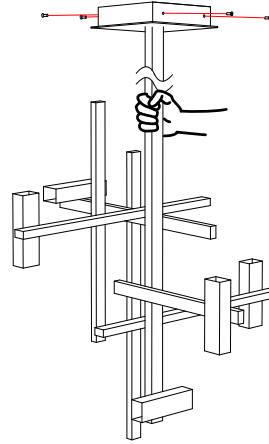

- ④ Fix the crystal diffusers in the proper position following the instruction attached.

Fissare i diffusori di cristallo nella posizione corretta seguendo le istruzioni fornite.

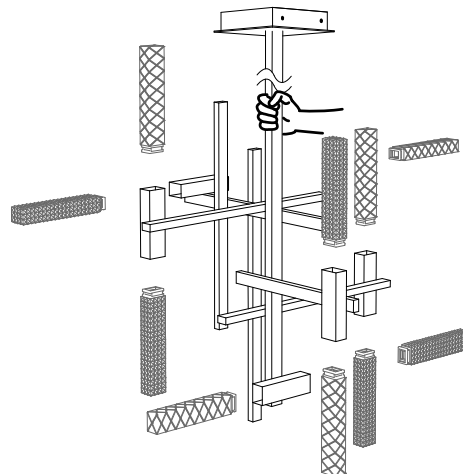

- ⑤ Some tubes of the structure may tilt after fixing the diffusers, make sure that all the lamp is in the correct configuration. Straighten the tubes and finally tighten the screws with a flat-blade screwdriver.

Fissando i diffusori è possibile che alcuni tubi della struttura si inclinino, assicurarsi che tutta la lampada sia nella configurazione corretta.
Raddrizzare i tubi ed infine stringere le viti con un cacciavite a punta piatta.

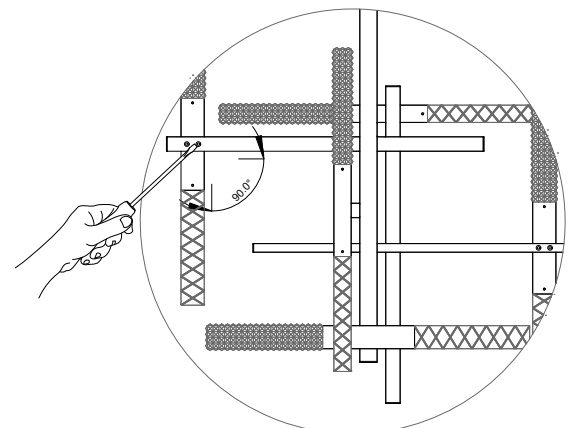

ALL OPERATIONS MUST BE CARRIED OUT BY QUALIFIED PERSON



1. KIT



2. Insert the glass diffuser into the proper space, applying a little pressure in the sides.
Inserire il diffusore di vetro nel suo scompartimento, applicando una leggera pressione sui lati.



3. Screw the grain on the left side with the provided Allen Key.
Stringere il grano sul lato sinistro con la chiave fornita.



4. Screw the grain on the right side.
Stringere il grano sul lato destro.



5. Screw the grain on the back.
Stringere il grano sul lato posteriore.



6. Check that the glass diffuser is well fastened, then repeat the five steps for all the glasses.
Verificare che il vetro sia fissato bene, dopodichè ripetere i cinque passaggi per tutti i vetri.

MAXI JOLLY HC MD 50



DRIVER - TRASFORMATORE

Pag. 1/1

DRAWN BY

N.O.

Direct current dimmable (TRAILING EDGE-LEADING EDGE) electronic drivers with DIP-SWITCH
Alimentatori elettronici regolabili (IGBT-TRIAC) in corrente continua con DIP-SWITCH



IS 15885
(Part 2 / Sec 13)
R - 41049751

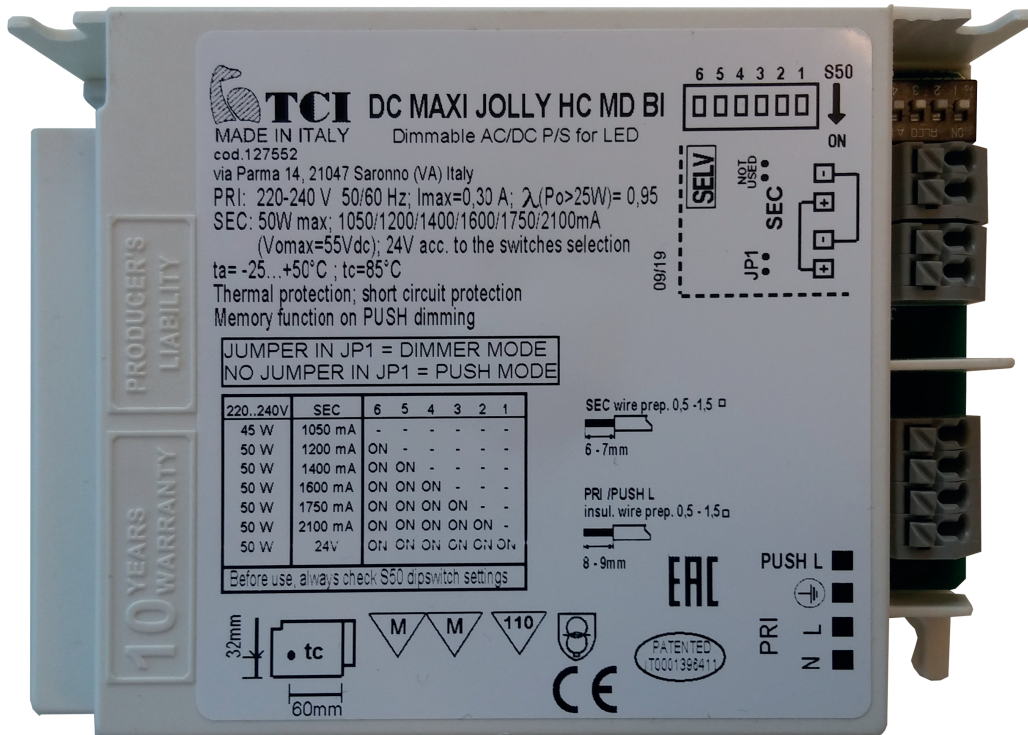

BUILT-IN SCREW FIXING Weight - Peso gr. 235 / 8,3 oz.
Compatible with ZHAGA (AM2) Pcs - Pezzi 40

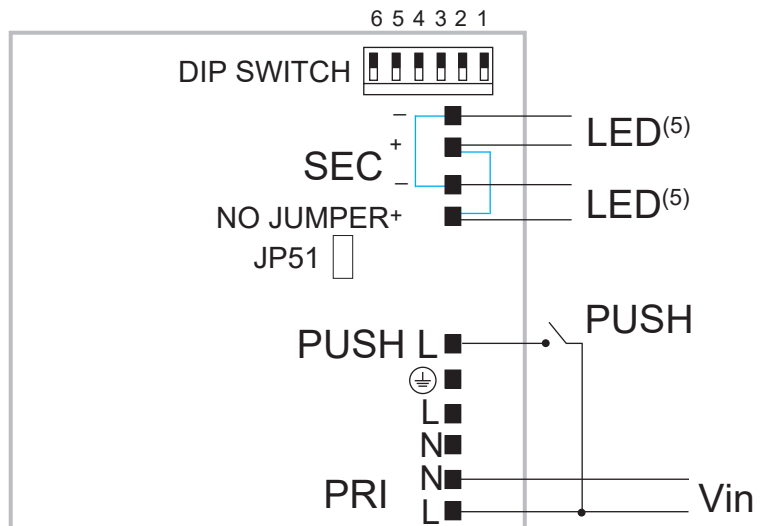
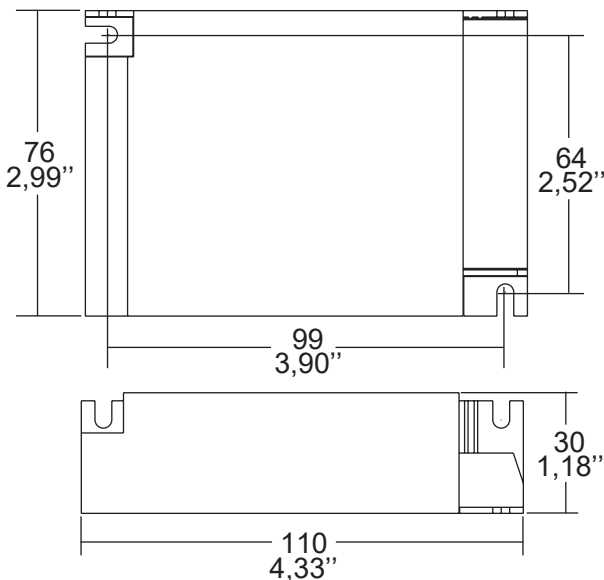

PUSH diagram - Collegamento PUSH
Internally wired - Collegato all'interno.